



ISI-500

Stand-alone Solar Inverter

Instruction Manual

1. Safety Guidelines (Please read through this manual before assembling the inverter)

- Risk of electrical shock and energy hazard. All failures should be examined by a qualified technician. Please do not remove the case of the inverter by yourself!
- Please do not install the inverter in places with high moisture or near water.
- Please do not install the inverter in places with high ambient temperature, under direct sunlight, or near fire source.
- Please only connect batteries with the same brand and model number in one battery bank. Using batteries from different manufacturers or different capacities is strictly prohibited!
- Never allow a spark or flame in the vicinity of the batteries, because they may generate explosive gases during normal operation.
- ISI-500 built-in the fan. Make sure the air flow from the fan is not obstructed at both sides (front and back) of the inverter. (Please allow at least 15cm of space)
- Please do not stack any object on the inverter as it may impede heat dissipation.
- Turn power off before removing batteries from the inverter.

⚠ WARNING: Batteries will have aging problem after years of operation. It is suggested to execute regular battery maintenance (e.g. every year). Once aged, the batteries should be changed by professional technician, or the failed batteries may cause fire or other hazards.

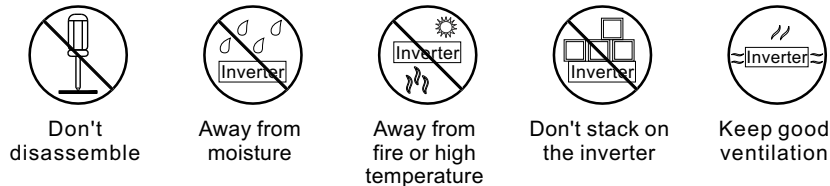

2. Introduction

- ISI-500 series combine a DC/AC Modified Sine Wave Inverter and a MPPT charger. The series is a high performance modified sine wave DC/AC inverter which can convert the DC electricity from a system consisting of batteries and solar panels and which are not just fully digitally controlled by an advanced microprocessor but also designed as a high frequency device.
- With modified sine wave output ISI-500 series can provide 500W continuously, 550W for 1 minute, and 1000W for 30 AC cycles.
- Designed as a high frequency device allows its weight lighter and increases its efficiency up to 88%.
- ISI-500 series built-in a MPPT solar charger, the maximum power rating of charging is 500W.
- The product designs concept for small independent power station. It is particularly used for areas to which electricity is difficult to be delivered, yet solar energy can be used as a power source in those areas.

2.1 Features

- 500W rated output
- Efficiency up to 88%
- Built-in multi-protection
- Fan ON/OFF controlled
- Complete LED indication for operation status
- Battery low alarm
- 2 years warranty
- AC output voltage regulation within $\pm 10\%$
- Fully digital controlled
- Compliance to FCC / CE
- Built-in 500W MPPT solar charger
- AC output voltage can be modified(optional) : 100/115/120VAC or 200/200/240VAC
- MPPT efficiency (Typ.):98%

2.2 Main Specifications

MODEL	112	124	148	212	224	248	
O U T P U T	RATED POWER	500W continuously ; 550W for 1 minute; 1000W for 30 AC cycles (112,212 Models : 350W continuously ; 385W for 1 minute; 700W for 30 AC cycles)					
	VOLTAGE / FREQUENCY	110Vac / 60Hz			230Vac / 50Hz		
	PROTECTION	Output Short, Over Load, and Over Temperature					
I N P U T	BAT. VOLTAGE	10.5 ~ 15.0V	21.0 ~ 30.0V	42.0 ~ 60.0V	10.5 ~ 15.0V	21.0 ~ 30.0V	42.0 ~ 60.0V
	DC CURRENT	35A	25A	12.5A	35A	25A	12.5A
	EFFICIENCY	85%	87%	87%	86%	88%	88%
	OFF MODE CURRENT DRAW	Under 1.0mA at power switch OFF					
PROTECTION	Over current, battery reverse polarity, battery low alarm, and battery low shutdown						

MODEL	112	124	148	212	224	248
SOLAR PANEL INPUT						
VOLTAGE RANGE	20~40V	35~80V	70~160V	20~40V	35~80V	70~160V
MAX. SHORT CIRCUIT CURRENT	15A	15A	7.5A	15A	15A	7.5A
RATED CHARGE POWER	350W	500W	500W	350W	500W	500W
CHARGER OUTPUT						
MAX. CHARGING VOLTAGE	14V	28V	56V	14V	28V	56V
MAX. CHARGING CURRENT	25A	20A	10A	25A	20A	10A

3. User Interface

3.1 Front Panel

Ⓐ **AC Output outlet** : To satisfy application demand of different geographic areas all over the world, there are many optional AC outlets to choose from.

Receptacle type						
	TYPE-A	TYPE-B	TYPE-C	TYPE-D	TYPE-E	TYPE-U
Country	USA	EUROPE	AUSTRALIA	U.K	AUSTRALIA	UNIVERSAL
Certificate	FC	CE	CE	CE	FC	None

Ⓑ **LED Indicator Status** : Operating status of ISI-500 will be displayed.

Ⓒ **POWER ON/OFF switch** : It is used to turn ISI-500 on or off.

Ⓓ **Ventilation holes** : It aids in cooling the ISI-500 down and improving its reliability. In addition, adequate ventilation is required for proper operating so as not to decrease its lifespan.

Ⓔ **Battery low alarm** : The alarm circuit is equipped with a relay. When it detects a low battery voltage level, the relay is de-energized. As a result, the contacts are disconnected. And the ISI-500 will send out a "Beep" sound to warn the users.

Low battery voltage	Contacts are disconnected	"Beep" warning
Normal battery voltage	Contacts are connected	-----

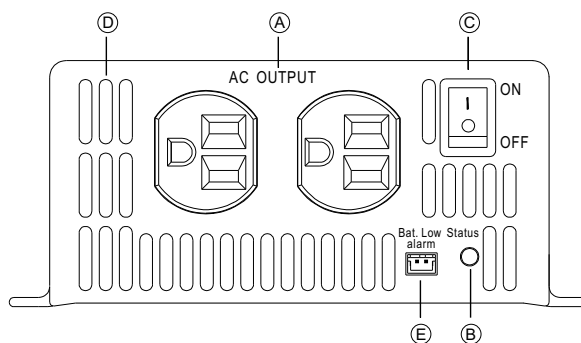

Figure 3.1 Front panel(Type A)

3.2 LED Indicator On Front Panel

Status LED : Represent the operating status of ISI-500.

LED Display	Green	Orange	Red
Light	Normal operating	Over load alarm (Less than a minute does not protect)	Over temperature or Over load protection
Flashing	Normal operating & Charging	Battery under voltage protection & Charging	Abnormal battery voltage protection

3.3 Rear Panel

- Ⓐ Battery input terminal(+),(-).
- Ⓑ Ventilation holes.
- Ⓒ Solar panel input terminal (+),(-).

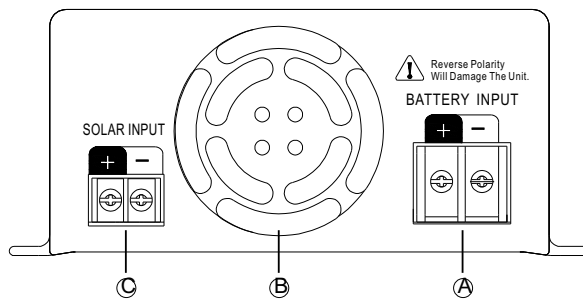

Figure 3.2 Rear Panel

4.Explanation of Operating Logic

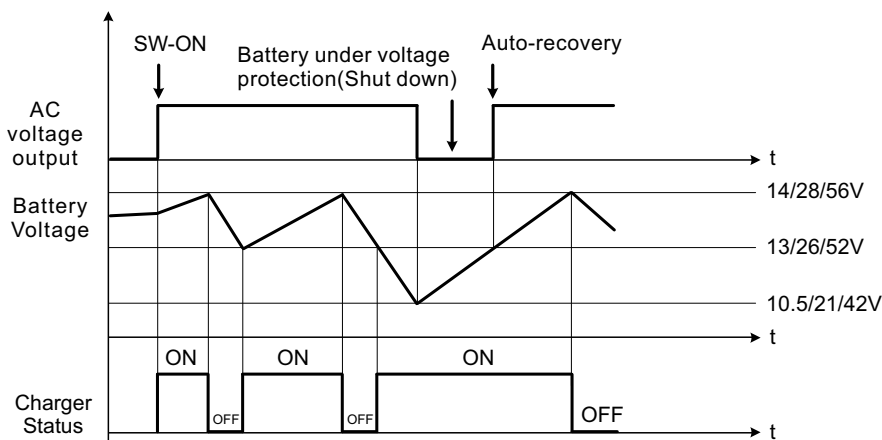

Figure 4.1 Process Control Diagram

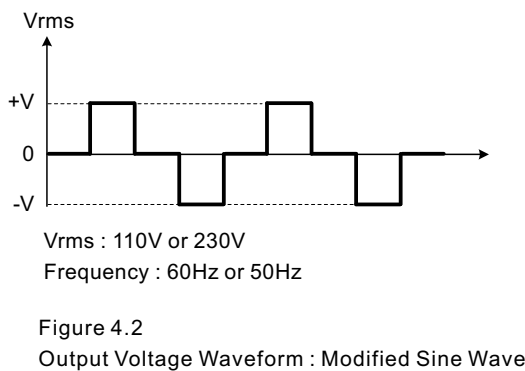

Figure 4.2
Output Voltage Waveform : Modified Sine Wave

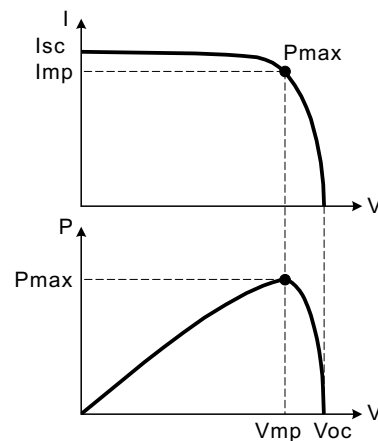

Figure 4.3 Maximum power point tracking curve

5.Protection

5.1 Input Protection

- (A) Battery polarity protection :** If the battery input is connected in reverse polarity, the internal fuse will blow and the inverter should be send back to MEAN WELL or our authorized distributors for repair.
- (B) Battery Under Voltage Protection :** When the battery voltage is lower than the preset value, the inverter will automatically terminate the output and "Battery low alarm" on the front panel will open. Please refer to 3.1(Ⓔ) .
- (C) Battery over voltage protection :** When battery voltage is too high, inverter automatically shuts down and the built-in buzzer sounds. Turn off the inverter. Then make sure the battery is within the proper voltage range, before restarting the unit.

⚠ WARNING:

Please choose suitable batteries that is within the rated input DC voltage range of ISI-500 (refer to spec).
 If the input DC voltage is too low (ex. using 12Vdc battery bank for 24Vdc input models), the inverter cannot startup properly.
 If the input DC voltage is too high (ex. using 48Vdc battery bank for 24Vdc input models), the inverter will get damaged !

5.2 Output Protection

If any abnormal situation occurs, the red LED on the display panel will be exhibited to show that ISI-500 is under fault situation.

(A)Over temperature protection : When the internal temperature is higher than ISI-500's safe operating temperature, OTP activates leading to automatic shutdown. Before restarting the unit, at least 30 minutes may be needed for cooling.

(B)AC output short circuit protection : When a short circuit situation occurs at the output of ISI-500, the unit will shut down and should be restarted again.

(C)Output overload protection : When the output is overloaded between 500W~550W, the inverter can continuously provide power for 1 minute. After that, if the overload condition is not removed, the overload protection will be activated.

6. Installation & Wiring

(A)Wiring for Batteries : Wiring connections should be as short as possible and less than 1.5 meters. Make sure suitable wires are chosen based on safety requirement and rating of current. Too small of a cross-section will result in overheating that could induce certain danger. Please refer to Table 6-1 and consult our authorized distributors if you have any questions.

Table 6-1 Suggestion for Wire Selection

Rated Current of Equipment (Amp)	Cross-section of Lead(mm ²)	AWG	Suggested Models
10A ~ 13A	1.25	16	148/248
13A ~ 16A	1.5	14	
16A ~ 25A	2.5	12	Solar panel input line
25A ~ 32A	4	10	124/224
32A ~ 40A	6	8	112/212

(B)Suggested battery type and capacity

Battery type	Lead-acid battery					
Battery Capacity	112	212	124	224	148	248
	12V / 120Ah ~ 12V / 400Ah		24V / 60Ah ~ 24V / 200Ah		48V / 30Ah ~ 48V / 100Ah	

Note: If you are using non lead acid batteries, please make sure those batteries are capable or contact the makers of those batteries to receive the information of their capacity.

(C)Requirements of Installation

- The mounting system and location must be suitable for the ISI-500's weight and dimension, allow at least 15cm of clearance around the inverter for proper cooling. Mounting the unit in a high dust or high moisture environment, as well as operating the unit in a high ambient temperature environment or with heavy load, could affect its lifespan.

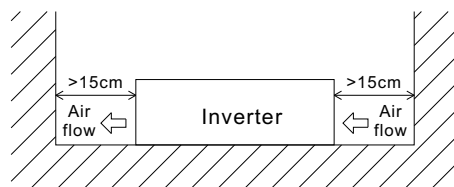
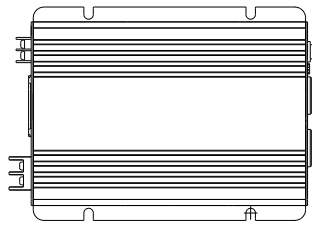

Figure 6.1 Example of Installation

(D) Mounting Suggestion

The inverter construction has two mounting holes on both sides of the housing, these mounting holes can be used to mount ISI-500 for a valid installation. It is recommended, mount ISI-500 on a horizontal surface. Besides, make sure the ventilation openings are free from obstruction.



(E) Example of system diagram

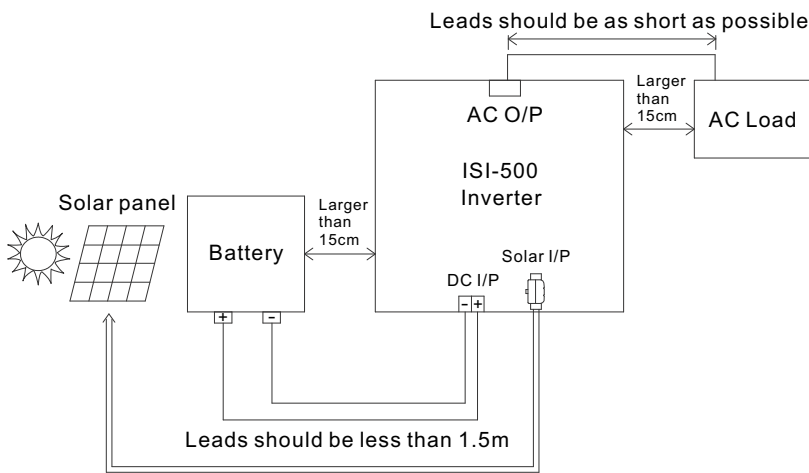

Based on the actual length of wiring, choose suitable cross-section of the leads

(F) Derating

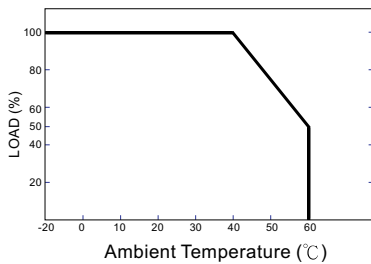

Figure 6.2 Output Derating Curve

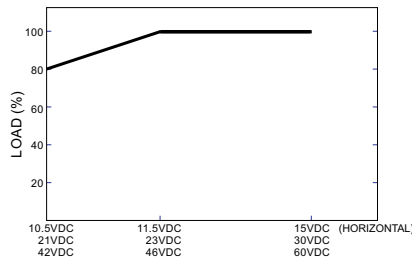

Figure 6.3 Input Derating Curve

7.Failure Correction Notes

ISI-500 is a complex product which should be serviced by a professional technician, any improper use or alteration either internally or externally may damage the unit or result in shock hazard. It is suggested, read the table below before troubleshooting on the inverter. If you are unable to judge the fault conditions, please contact MEAN WELL or any of our distributors for repair service.

Failure status	Possible reasons	Recommended solutions
No AC output voltage	Abnormal input voltage	Make sure battery voltage is not too low or too high
	Over temperature protection	Make sure that the ventilation is not block and the ambient temperature is not too high. Please derate load usage or lower the ambient temperature
	Overload protection	Make sure the output load does not exceed the rated value or the peak startup current is not too high, typically found in inductive or capacitive loads
	Short circuit protection	Make sure the output is not overloaded or short circuited
Discharging period for battery is too short	Battery aged or broken	Replace the batteries
	Battery capacity is too small	Reconfirm battery specification and enlarge the battery capacity as suggested

8.Warranty

Two years of warranty is provided under normal operating conditions. Please do not change components or modify the unit by yourself or attempt to repair the unit by yourself because Mean Well reserves the right to void the warranty.